

Group code Code de groupe

INDIAN REGISTER EVENTS REPORTING SUMMARY
SOMMAIRE DES ÉVÉNEMENTS À RAPPORTER AU REGISTRE DES INDIENS

11 pgs

District	
Group name - Nom du groupe	Number of data entry forms Nombre de formulaires d'entrée de données

(Adult)

* Application For registration and
Secure Certificate of Indian status

Pg. 1-6

* Instructions For Adult CIS

Pg. ~~1-6~~ 1-4

Signature of District or Band Manager - Signature de l'administrateur du district ou de la bande

Date

Y/A

M



APPLICATION FOR REGISTRATION ON THE INDIAN REGISTER AND FOR THE SECURE CERTIFICATE OF INDIAN STATUS (SCIS) (FOR ADULTS 16 YEARS OF AGE OR OLDER)

GENERAL INFORMATION

- ▶ Please review the instructions (83-168E-I) to complete the application.
- ▶ To complete the application, you may need to include a Guarantor Declaration (form 83-169E) or a Statutory Declaration in Lieu of Guarantor (form 83-170E). A Declaration is required if the application is sent by mail.
- ▶ To obtain forms or the instructions, visit canada.ca/indian-status, or call 1-800-567-9604.
- ▶ Original documents included with the application will be returned to you.
- ▶ If you need to include a Guarantor Declaration form with the application, you must submit the form with the **signature of the guarantor**. A guarantor is a person who can confirm your identity.

HOW TO SUBMIT YOUR APPLICATION

IN PERSON:

- At the regional office nearest you. As an appointment may be required, it is recommended that you call ahead of time.
- For the list of regional offices, visit canada.ca/indian-status, or call 1-800-567-9604.

BY MAIL:

- If you send the application by mail, you must include a Guarantor Declaration form with the **signature** of the guarantor.
- The guarantor must sign and date the photocopies of the front and back of your supporting identity documents.
Note: You must still include your **original** proof of birth document.
- If you are applying for registration AND for the Secure Certificate of Indian Status, the guarantor must also sign and date the back of one (1) of your photos and write the statement "this is a true likeness of (your name)".

Send the application to:

National Registration Processing Unit
10 Wellington Street
Gatineau, Quebec K1A 0H4

For applications made under Bill S-3: *An Act to amend the Indian Act in response to the Superior Court of Quebec decision in Descheneaux c. Canada (Procureur général)*, or under Bill C-3: *Gender Equity in Indian Registration Act*, send to:

Application Processing Unit
Box 6700
Winnipeg, Manitoba R3C 5R5



CHECKLIST

Application Form

- Section 7 of the application must be signed and dated.
-

Birth Document

- Include an **original** birth certificate listing the **names of your parents**. A photocopy is not acceptable.

Note: If you were adopted, you must provide an original birth certificate listing the names of the your **adoptive parent(s)**.

Supporting Identity Documents

Supporting identity documents must contain the following four (4) elements: full name, date of birth, photo and signature.

► **Include with the application:**

- One (1) identity document that contains all the elements listed above, OR
- More than one identity document that, combined together, contain all the elements listed above, OR
- One (1) identity document that contains some but not all the elements listed above and a Guarantor Declaration form.

► **You may include:**

- Original** identity documents (recommended if submitting the application in person), OR
- Photocopies** of the supporting identity documents and a **Guarantor Declaration form**. The guarantor must sign and date the photocopies of the front and back of the identity documents (recommended if sending the application by mail).
-

Name-Linking Document(s)

If you are applying under a name that is different than the name on your birth certificate, you must provide a name-linking document, such as a marriage certificate and a legal name change certificate.

► **If applicable, include with the application:**

- An **original** name-linking document, OR
- A **photocopy** of the name-linking document and a photocopy of a government-issued identity document that has your name as it appears on the application form (for example, a driver's licence).
-

Photos

- Include two (2) unaltered, identical, Canadian passport-style photos. The name and address of the studio or person who took the photo, and the date the photo was taken must be indicated on the back of one (1) photo. Photos are required only if a Secure Certificate of Indian Status is requested.
-

Adoption

► **If you were adopted as a child, include with the application:**

- A photocopy of the **adoption order** or photocopy of the **letter from the Social Services authorities** confirming the details of the adoption: names of the adoptive parent(s), full name of adoptee as it appears on the adoption order, and date and place of adoption.
- A signed and dated consent form giving the Indian Registrar permission to contact the Social Services authorities for information on your birth ancestry. To obtain the consent form, call 1-800-567-9604.
- A photocopy of your pre-adoption birth certificate (optional, if available).
-

Mail-In Application

- If submitting the application by mail, include a Guarantor Declaration form (see instructions on previous page).
-



SECTION 3: Document Requirements

A. Proof of Birth Document Original document included

Registration Number on Birth Document	Province/Territory of Issuance	State (USA) of Issuance
---------------------------------------	--------------------------------	-------------------------

B. Name Linking Document(s)
(Provide if the name used on this application is different than the name listed on your proof of birth document)

Name (exactly as it appears on the document)	Document Type

C. Supporting Identity Document(s)

Document Type	Document Number	Expiry Date (YYYYMMDD) (if applicable)
Name (exactly as it appears on the document)		

Document Type	Document Number	Expiry Date (YYYYMMDD) (if applicable)
Name (exactly as it appears on the document)		

Document Type	Document Number	Expiry Date (YYYYMMDD) (if applicable)
Name (exactly as it appears on the document)		

SECTION 4: Adoption Information

(Complete this section ONLY if you were adopted as a child)

I was adopted as a child, and I believe that I have entitlement to Indian status through (select all that apply)

My adoptive mother My adoptive father My birth mother My birth father

Adoptive Mother

Family Name	Given Name(s)	Date of Birth (YYYYMMDD)
-------------	---------------	--------------------------

Adoptive Father

Family Name	Given Name(s)	Date of Birth (YYYYMMDD)
-------------	---------------	--------------------------

Birth Mother (if known)

Family Name	Given Name(s)
-------------	---------------

Birth Father (if known)

Family Name	Given Name(s)
-------------	---------------

▶ If you believe that you are entitled to Indian status through your adoptive parent(s), complete the Family Information (section 5) with your adoptive parents' information.

▶ If you believe that you are entitled to Indian status through your birth parent(s), complete the Family Information (section 5) with your birth parents' information, if available.



SECTION 5: Family Information

A. Father

Family Name		Family Name at Birth (if different)	Given Name(s)
Date of Birth (YYYYMMDD)	First Nation/Band Name		First Nation/Band (3 digits) Number or Registration (10 digits) Number
Was the father adopted? <input type="radio"/> Yes <input type="radio"/> No <input type="radio"/> Unknown <input type="checkbox"/> Parent not stated on the birth document			

B. Mother

Family Name		Family Name at Birth (if different)	Given Name(s)
Date of Birth (YYYYMMDD)	First Nation/Band Name		First Nation/Band (3 digits) Number or Registration (10 digits) Number
Was the mother adopted? <input type="radio"/> Yes <input type="radio"/> No <input type="radio"/> Unknown			

C. Maternal Grandparents

(Provide information up to the first person registered. For example, if your mother is registered, information on the grandparents and great-grandparents is not required)

Family Name	Family Name at Birth (if different)	Given Name(s)	Date of Birth (YYYYMMDD)	First Nation/Band Name or Registration No.	Adopted Yes/No
Grandfather					
Grandmother					
Great-Grandfather (1)					
Great-Grandmother (1)					
Great-Grandfather (2)					
Great-Grandmother (2)					

D. Paternal Grandparents

(Provide information up to the first person registered. For example, if your father is registered, information on the grandparents and great-grandparents is not required)

Family Name	Family Name at Birth (if different)	Given Name(s)	Date of Birth (YYYYMMDD)	First Nation/Band Name or Registration No.	Adopted Yes/No
Grandfather					
Grandmother					
Great-Grandfather (1)					
Great-Grandmother (1)					
Great-Grandfather (2)					
Great-Grandmother (2)					



Additional Family Information (optional): List the names of other registered relatives such as brothers, sisters, aunts, uncles, cousins. (Add separate pages if additional space is required)

SECTION 6: Photo and Signature to Appear on the Secure Certificate of Indian Status (SCIS)

Select what applies to you.

- Two (2) unaltered, identical, Canadian passport-style photographs are included / SCIS not requested

Sign your name inside the box without touching the borders. You may sign with an "X", in syllabics or another language, as long as this is your usual legal signature.

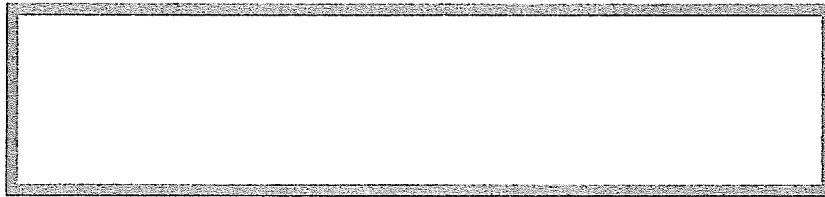

SECTION 7: Declaration and Signature

Failing to sign and date the declaration will delay the processing of your application.

I solemnly declare that all statements made in this application are true, all documents provided to support this application are unaltered, and the enclosed photographs (if requesting a Secure Certificate of Indian Status) are a true likeness of me. I have read and understand the Notice to Applicants and the Privacy Act Statement.

If eligible, I (Print Name), request to be registered in the Indian Register and, if applicable, to have

my name entered on a First Nation/Band List, as provided for under the Indian Act. I further request to have a Secure Certificate of Indian Status issued to me (if applicable).

Signature / Date (YYYYMMDD) X

SECTION 8: Indian Registration Administrator (IRA)

If an IRA assisted in completing this form, he or she must complete and sign this section.

Name / First Nation/Band Number or Initiator Code / IRA Signature / Date (YYYYMMDD) X



INSTRUCTIONS

SECURE CERTIFICATE OF INDIAN STATUS (SCIS)

APPLICATION FOR ALREADY REGISTERED PERSONS

ADULTS (16 YEARS OF AGE OR OLDER), CHILDREN (15 YEARS OF AGE OR YOUNGER) AND DEPENDENT ADULTS

GENERAL INFORMATION

- ▶ This guide is for already registered persons who are submitting an application to obtain the Secure Certificate of Indian Status (form 83-172E).
- ▶ To obtain forms, visit www.canada.ca/indian-status, or call 1-800-567-9604.
- ▶ To complete the application, you may need to include a [Guarantor Declaration \(form 83-169E\)](#) or a [Statutory Declaration in Lieu of Guarantor \(form 83-170E\)](#).

A guarantor is a person who can confirm the identity of the adult applicant (16 years of age or older) or the identity of the parent or legal guardian who is applying for a child (15 years of age or younger) or a dependent adult. A guarantor must meet the criteria detailed on the Guarantor Declaration form.

If a Guarantor Declaration is needed, you must submit the form with the **signature of the guarantor**.

If an eligible guarantor is not available, the adult applicant or the applying parent / legal guardian must provide two (2) references who can confirm his/her identity. The Statutory Declaration in Lieu of Guarantor must be completed and signed before a commissioner for oaths, notary public or lawyer.

HOW TO SUBMIT THE APPLICATION

IN PERSON:

- At the regional office nearest you. As an appointment may be required, it is recommended that you call ahead of time.
- For the list of regional offices, visit www.canada.ca/indian-status, or call 1-800-567-9604.

BY MAIL:

- If you send the application by mail, you must include a Guarantor Declaration form with the **signature** of the guarantor.
- The guarantor must sign and date the photocopies of the front and back of your identity document(s).
- The guarantor must also sign and date the back of one (1) of the two photos and write the statement "this is a true likeness of (name of adult, child or dependent adult)".

Send the application to:

**National SCIS Processing Unit
10 Wellington Street
Gatineau, Quebec K1A 0H4**

PHOTO SPECIFICATIONS

- ▶ You must provide two (2) identical and unaltered Canadian passport-style photos, taken within the last twelve (12) months of the date of this application.

Note: U.S. passport photo specifications do not meet SCIS photo requirements.

The photos must meet the following requirements:

- Photo size: 50 mm wide x 70 mm high (2 inches wide x 2 7/16 inches high).
- The face, from chin to crown of the head, must measure between 31 and 36 mm (1 1/4 inch and 1 7/16 inch).
- Photos must be originals and not taken from an existing photograph.
- Photos must be printed on plain, high quality photographic paper. Heavyweight paper is not acceptable.
- The image must be clear, sharp and in focus. Photos can be in color or black and white.
- Facial features must appear clearly against a white or light-coloured background.
- Photos must be taken with uniform lighting without shadows, glare or flash reflections.
- The photo must show a full front view of the face and top of the shoulders squared to the camera, and centered in the photo.
- The face must show a neutral expression (mouth closed, eyes open and clearly visible).
- Glasses, including tinted prescription glasses, may be worn as long as the eyes are clearly visible and there is no glare on the face or glasses. Sunglasses are not acceptable.
- Hats and other head coverings must not be worn, except for religious or medical reasons. If worn, the hat or other head covering must not cast shadows on the face and the full face must be clearly visible.
- For a child, the photo must show the child's head and shoulders only. Parent's or child's hands must not appear in the photo.
- For newborns, the photo may be taken while the child is sitting in a car seat, as long as a white blanket is placed over the seat behind the child's head.

The following must appear on the back of one (1) photo:

- The name and address of the studio or person who took the photo, and the date the photo was taken (not the date the photo was printed).
- If you are submitting the application by mail, your guarantor must sign, date, and write the statement: "this is a true likeness of (name of adult, child, dependent adult)".

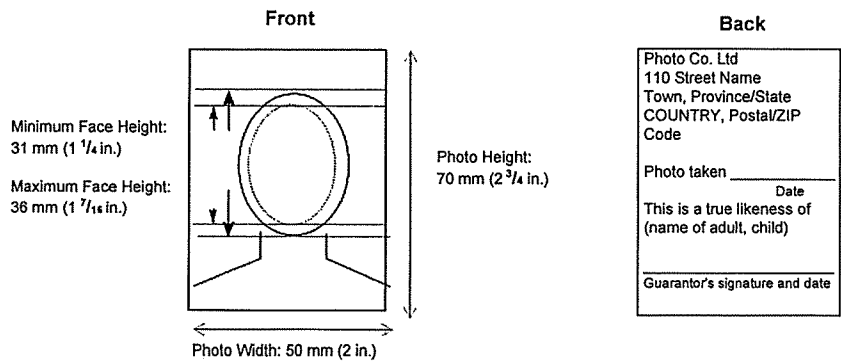

Image is not the actual size (refer to specified measurements)



ADULT (16 YEARS OF AGE OR OLDER) APPLICATION

Note: SCIS is the abbreviation for Secure Certificate of Indian Status.

Instructions for a Simplified Renewal

If you meet these four (4) conditions: 1) you were 16 years of age or older when you last applied for an SCIS; 2) your personal information has not changed (name and/or band affiliation); 3) your SCIS has not been revoked or reported lost, stolen, damaged or destroyed; and 4) this application is made no later than 12 months past the renewal date indicated on your SCIS:

1. Complete sections 1, 3, 5; **please sign and date section 6**; complete section 7, if applicable.
2. Include two (2) Canadian passport-style PHOTOS (refer to photo specifications).
3. Include your SCIS as your **IDENTITY DOCUMENT** (section 3). No other identity document is required.
4. **If submitting the application in person**, it is recommended that you bring your SCIS with you; a photocopy will be made on site and you will retain your SCIS. A photocopy of your SCIS is acceptable if you include a Guarantor Declaration form and the guarantor signs and dates the photocopy of the front and back of your SCIS (recommended if you send the application by mail).

If submitting the application by mail, the guarantor must also sign and date the back of one (1) photo and write the statement "this is a true likeness of (your name)".

Instructions for All Other Adult Applications

1. Complete all applicable sections of the form; **please sign and date section 6**.
2. Include two (2) Canadian passport-style PHOTOS (refer to photo specifications).
3. Include your **IDENTITY DOCUMENT(S)** (section 3). Select **ONE** of the following five options based on the documents that you have.

Option 1 - **ONE (1) document** that contains your name, date of birth, photo and signature, among these: 1) passport; 2) driver's licence; 3) Canadian military identification document; 4) identification card issued by a province or territory; 5) provincial, territorial or federal Correctional Services identity document (with or without a signature); 6) health card issued by a province or territory if it shows your name, date of birth, photo and signature; 7) Canadian citizenship card issued prior to February 1, 2012; 8) Canadian permanent resident card with signature (issued before February 4, 2012); 9) U.S. permanent resident card. **Your identity document must not be expired.**

Option 2 - **More than one of the following documents** that, when combined together, contain your name, date of birth, photo and signature: 1) health card issued by a province or territory; 2) government employee identification card; 3) Canadian permanent resident card without signature (issued after February 4, 2012); 4) U.S. passport card; 5) NEXUS or FAST card; 6) firearms license; 7) U.S. Old Age Security card. **Your identity documents must not be expired.**

Option 3 - Your **Secure Certificate of Indian Status** (SCIS) and one (1) identity document listed under option 2 **OR** your SCIS and a Guarantor Declaration form. You may use your SCIS **only if** this application is submitted no later than 12 months past the renewal date indicated on your SCIS.

Option 4 - Your **Certificate of Indian Status** (CIS) and one (1) identity document listed under option 2 **OR** your CIS and a Guarantor Declaration form. You may use your CIS **only if** this application is submitted no later than 6 months past the expiry date indicated on your CIS.

Option 5 - **ONE (1) identity document listed under option 2** and a Guarantor Declaration form. The guarantor must sign and date the back of one (1) photo.

Note: You may include your original identity document(s) (recommended if submitting your application in person) **OR** a photocopy of the front and back of your identity document(s) and a Guarantor Declaration form (recommended if you send the application by mail). The photocopies must be signed and dated by the guarantor.

4. Include **NAME-LINKING DOCUMENT(S)** (section 4), if applicable. If you changed your name, a legal document linking your previous name with your current name must be provided, such as a name change certificate, a marriage certificate, a divorce order, or an amended birth certificate with your current name and the names of your parents. If name-linking documents were provided previously, you do not need to provide them again.

You may include an original name-linking document **OR** a photocopy of the name-linking document and a photocopy of a government-issued identity document with your current name (for example, a driver's licence).

5. **If submitting the application by mail**, include a Guarantor Declaration form and follow the instructions on page 1.
-



CHILD (15 YEARS OF AGE OR YOUNGER) / DEPENDENT ADULT APPLICATION

Note: SCIS is the abbreviation for Secure Certificate of Indian Status.

1. Complete all applicable sections of the form; please sign and date section 6.

2. Include the required documents for the child or dependent adult:

- Two (2) Canadian passport-style PHOTOS (refer to photo specifications).
- Photocopy of the most recent LEGAL DOCUMENTS (such as a divorce judgment, separation agreement, custody or guardianship order) proving custody or guardianship of the child to the applying parent/guardian. If there are legal documents, they must be provided.
- Photocopy of the ORDER OF GUARDIANSHIP for the dependent adult.
- NAME-LINKING DOCUMENT(S) (section 4). If the name of the child or dependent adult has changed, a legal document linking the previous name with the current name of the child or dependent adult must be provided, such as a name change certificate or an amended birth certificate with the current name and the names of the parents. If name-linking documents were provided previously, you do not need to provide them again.

You may include an original name-linking document OR a photocopy of the name-linking document and a photocopy of a government-issued identity document with the current name of the child or dependent adult (for example, a health card).

3. Include the parent's or legal guardian's IDENTITY DOCUMENT(S) (section 3). Select ONE of the following five options based on the documents that you have.

Option 1 - Your Secure Certificate of Indian Status (SCIS) if this application is submitted no later than 12 months past the renewal date indicated on your SCIS.

Option 2 - Your Certificate of Indian Status (CIS) if this application is submitted no later than 6 months past the expiry date indicated on your CIS.

Option 3 - ONE (1) document that contains your name, date of birth, photo and signature, among these: 1) passport; 2) driver's licence; 3) Canadian military identification document; 4) identification card issued by a province or territory; 5) provincial, territorial or federal Correctional Services identity document (with or without a signature); 6) health card issued by a province or territory if it shows your name, date of birth, photo and signature; 7) Canadian citizenship card issued prior to February 1, 2012; 8) Canadian permanent resident card with signature (issued before February 4, 2012); 9) U.S. permanent resident card. **Your identity document must not be expired.**

Option 4 - More than one of the following documents that, when combined together, contain your name, date of birth, photo and signature: 1) health card issued by a province or territory; 2) government employee identification card; 3) Canadian permanent resident card without signature (issued after February 4, 2012); 4) U.S. passport card; 5) NEXUS or FAST card; 6) firearms license; 7) U.S. Old Age Security card. **Your identity documents must not be expired.**

Option 5 - ONE (1) identity document listed under option 4 and a Guarantor Declaration form. The guarantor must sign and date the back of one (1) photo.

Note: You may include your original identity document(s) (recommended if submitting your application in person) OR a photocopy of the front and back of your identity document(s) and a Guarantor Declaration form (recommended if you send your application by mail). The photocopies must be signed and dated by the guarantor.

4. Include a photocopy of NAME-LINKING DOCUMENT(S) for the parent or legal guardian (section 4), if applicable. If your name as it appears on your identity document(s) is not the same as the name that appears on the legal custody or guardianship documents that you are including with this application, or on documents previously provided to the Department (for example, the child's birth certificate that was provided at the time of his or her registration), you must provide a legal document linking your previous name with your current name. Examples of name-linking documents include: a name change certificate, a marriage certificate, a divorce order, or an amended birth certificate with your current name and the names of your parents. If name-linking documents were provided previously, you do not need to provide them again.

5. If submitting the application by mail, include a Guarantor Declaration form and follow the instructions on page 1.