

Group code Code de groupe

INDIAN REGISTER EVENTS REPORTING SUMMARY
SOMMAIRE DES ÉVÉNEMENTS À RAPPORTER AU REGISTRE DES INDIENS

13 pgs

District	
Group name - Nom du groupe	Number of data entry forms Nombre de formulaires d'entrée de données

(Child)

* Application For registration and
Secure Certificate of Indian status
Pg. 1-6

* Instructions For child CTS
Pg. 1-6

Signature of District or Band Manager - Signature de l'administrateur du district ou de la bande

Date

Y/A

M



**APPLICATION FOR REGISTRATION ON THE INDIAN REGISTER AND
FOR THE SECURE CERTIFICATE OF INDIAN STATUS (SCIS)
(FOR CHILDREN 15 YEARS OF AGE OR YOUNGER OR DEPENDENT ADULTS)**

GENERAL INFORMATION

- ▶ Please review the instructions ([83-1711E](#)) to complete the application.
 - ▶ To complete the application, you may need to include a [Guarantor Declaration \(form 83-169E\)](#) or a [Statutory Declaration in Lieu of Guarantor \(form 83-170E\)](#). A Declaration is required if the application is sent by mail.
 - ▶ To obtain forms or the instructions, visit [canada.ca/indian-status](#), or call 1-800-567-9604.
 - ▶ If original documents are included with the application, they will be returned to you.
 - ▶ If you need to include a Guarantor Declaration form with the application, you must submit the form with the **signature of the guarantor**. A guarantor is a person who can confirm the identity of the applying parent/legal guardian.
-

HOW TO SUBMIT THIS APPLICATION

IN PERSON:

- At the regional office nearest you. As an appointment may be required, it is recommended that you call ahead of time.
- For the list of regional offices, visit [canada.ca/indian-status](#), or call 1-800-567-9604.

BY MAIL:

- If you send the application by mail, you must include a Guarantor Declaration form with the signature of the guarantor.
- The guarantor must sign and date the photocopies of the front and back of the supporting identity documents of the applying parent/legal guardian.
Note: You must still include the original proof of birth document for the child/dependent adult.
- If you are applying for registration AND for the Secure Certificate of Indian Status, the guarantor must also sign and date the back of one (1) photo and write the statement "this is a true likeness of (name of the child or dependent adult)".

Send the application to:

**National Registration Processing Unit
10 Wellington Street
Gatineau, Quebec K1A 0H4**

For applications made under Bill S-3: *An Act to amend the Indian Act in response to the Superior Court of Quebec decision in Descheneaux c. Canada (Procureur général)*, or under Bill C-3: *Gender Equity in Indian Registration Act*, send to:

**Application Processing Unit
Box 6700
Winnipeg, Manitoba R3C 5R5**



CHECKLIST

Signatures and Legal Documents

- Section 9 of the application is dated and signed by both parents, or by the custodial parent or legal guardian(s).
- If applicable, include photocopies of the most recent legal documents (such as a divorce judgment, separation agreement, custody or guardianship order) proving custody or guardianship to the applying parent/legal guardian.

Documents Required for the Child/Dependent Adult

- Original birth certificate listing the names of the parents. A photocopy is not acceptable.

Note: If the child or dependent adult was adopted, you must provide an original birth certificate listing the names of the adoptive parent(s).

If the child/dependent adult is to be registered and/or issued a Secure Certificate of Indian Status under a name other than the name listed on the birth certificate, you must provide a name-linking document, such as a legal name change certificate.

► If applicable, include with the application:

- An original name-linking document, OR
 - A photocopy of the name-linking document and a photocopy of a government-issued identity document that has the name of the child/dependent adult as it appears on the application (for example, a health card).
- Two (2) unaltered, identical, Canadian passport-style photos of the child/dependent adult. The name and address of the studio or person who took the photo, and the date the photo was taken must be indicated on the back of one (1) photo. Photos are required only if a Secure Certificate of Indian Status is requested.

Adoption

► If the child/dependent adult was adopted, include with the application:

- A photocopy of the adoption order or photocopy of the letter from the Social Services authorities confirming the details of the adoption: names of the adoptive parent(s), full name of adoptee as it appears on the adoption order, and date and place of adoption.
- A signed and dated consent form giving the Indian Registrar permission to contact the Social Services authorities for information on his/her birth ancestry. To obtain the consent form, call 1-800-567-9604.
- A photocopy of the pre-adoption birth certificate (optional, if available).

Documents Required for the Applying Parent/Legal Guardian

Supporting identity documents must contain the following four (4) elements: full name, date of birth, photo and signature.

► Include with the application:

- One or more identity documents that, combined together, contain all the elements listed above, OR
- One (1) identity document that contains some but not all the elements listed above and a Guarantor Declaration form.

► You may include:

- Original identity documents (recommended if submitting the application in person), OR
- Photocopies of the identity documents and a Guarantor Declaration form. The guarantor must sign and date the photocopies of the front and back of the identity documents (recommended if sending the application by mail).

- Include photocopies of name-linking documents, such as a marriage certificate and a legal name change certificate, if your name as it appears on the application is different than the name listed on your identity documents, legal documents (custody order, order of guardianship, etc.) or the birth certificate of the child/dependent adult.

If submitting the application by mail, include a Guarantor Declaration form (see instructions on previous page).



APPLICATION FOR REGISTRATION ON THE INDIAN REGISTER AND FOR THE SECURE CERTIFICATE OF INDIAN STATUS (SCIS) (FOR CHILDREN 15 YEARS OF AGE OR YOUNGER OR DEPENDENT ADULTS)

Privacy Act Statement

This statement outlines the purposes for the collection and use of personal information. Only information needed to respond to program requirements will be requested. Collection, use, and disclosure of personal information are in accordance with the *Privacy Act*. In some cases, information may be disclosed without your consent pursuant to subsection 8(2) of the *Privacy Act*. The authority to collect and use personal information for the Indian Registration and the Secure Certificate of Indian Status programs is derived from the *Indian Act*. We use the personal information we collect to determine entitlement to registration in the Indian Register and membership in a First Nation for which the Band List is maintained by the Department, to issue a Secure Certificate of Indian Status to registered persons, and for the provision of benefits and services conferred exclusively to those who are registered. We may share the personal information you provide as outlined under Personal Information Bank AANDC PPU110 (Info Source <http://www.aadnc-aandc.gc.ca/eng/1100100011039/1100100011040>). The information collected is retained by the Department for 30 years after the last administrative action and then transferred to Library and Archives Canada (or as described in the Personal Information Bank). As stated in the *Privacy Act*, you have the right to access the personal information you give us and request changes to incorrect information. If you have questions or wish to notify us of incorrect information, you may call us at 1-800-567-9604. For more information on privacy issues and the *Privacy Act* in general, you can consult the Privacy Commissioner at 1-800-282-1376.

NOTICE TO APPLICANTS

If you identify with an Indigenous group that is not recognized under the *Indian Act* (non-status), you may wish to consult with that group before proceeding with an application for registration for yourself, a minor child or dependent adult. Registration under the *Indian Act* in Canada may affect your entitlement to join or be recognized by some non-status groups and your entitlement to the programs and services they may offer. The Indian Registrar does not have the authority to remove a name from the Indian Register if the person has been correctly registered, even when the person requests to deregister.

The Secure Certificate of Indian Status (SCIS) remains at all times the property of the Government of Canada and must only be used by the person in whose name it is issued. Any false or misleading statement with respect to this application and any supporting document, including the concealment of any material fact, selling or permitting the use of your SCIS by any other person or agency may lead to criminal prosecution, and is cause for revocation of your SCIS and refusal to issue a SCIS in the future. Any false or misleading statement, including the concealment of any material fact, may lead to a review of your entitlement to registration and revocation of your registered Indian status.

► Complete this form online, or write in block letters using black or dark blue ink.

SECTION 1: Child/Dependent Adult Information

Family Name		Given Name(s)	
Family Name at Birth (if different from above)		Alias / Cultural Name (if applicable)	
Sex (as per Birth Certificate) <input type="radio"/> Male <input type="radio"/> Female		Date of Birth (YYYYMMDD)	
Permanent Address <input type="checkbox"/> Address is on Reserve			
Number, Street, Apartment, P.O. Box			
City/Town	Province/Territory (Canada)	State (USA)	Postal/ZIP Code

- If applying for a child: Are there separation agreements, court orders or legal proceedings pertaining to the custody of the child?
 No Yes ► If yes, include photocopies of all legal documents.
- If applying for a dependent adult, provide a photocopy of the Order of Guardianship.

SECTION 2: Document Requirements for Child/Dependent Adult

A. Proof of Birth Document <input type="checkbox"/> Original document included		
Registration Number on Birth Document	Province/Territory of Issuance	State (USA) of Issuance
B. Name Linking Document(s) (Provide if the name of the child/dependent adult on this application is different than the name listed on the proof of birth document)		
Name (exactly as it appears on the document)	Document Type	



SECTION 3: First Nation/Band Choice (If the parents are affiliated with different First Nations/Bands, indicate with which First Nation/Band you would like the child/dependent adult to be affiliated)

First Nation/Band Name	First Nation/Band Number (3 digits) (if known)
------------------------	--

SECTION 4: Parent(s)/Legal Guardian(s) Information

Note: Correspondence will be addressed to the applying parent/legal guardian unless instructed otherwise.

Applying Parent/Legal Guardian		Other Parent/Legal Guardian	
Family Name		Family Name	
Given Name(s)		Given Name(s)	
Mailing Address (if different than the permanent address of the child/dependent adult) Number, Street, Apartment, P.O. Box		Permanent Address (if different than the permanent address of the child/dependent adult) Number, Street, Apartment, P.O. Box	
City/Town	Province/Territory (Canada)	City/Town	Province/Territory (Canada)
State (USA)	Postal/ZIP Code	State (USA)	Postal/ZIP Code
Telephone Number (Daytime)	Telephone Number (Other)	Telephone Number (Daytime)	Telephone Number (Other)
Email Address		Email Address	
Is your permanent address the same as the child's/dependent adult's address? <input type="radio"/> Yes <input type="radio"/> No			
Relationship to Child/Dependent Adult: <input type="radio"/> Parent <input type="radio"/> Custodial Parent <input type="radio"/> Legal Guardian <input type="radio"/> Other (Specify): _____		Relationship to Child/Dependent Adult: <input type="radio"/> Parent <input type="radio"/> Custodial Parent <input type="radio"/> Legal Guardian <input type="radio"/> Other (Specify): _____	

SECTION 5: Document Requirements for Applying Parent/Legal Guardian

A. Supporting Identity Document(s)

Document Type	Document Number	Expiry Date (YYYYMMDD) (if applicable)
Name (exactly as it appears on the document)		

Document Type	Document Number	Expiry Date (YYYYMMDD) (if applicable)
Name (exactly as it appears on the document)		

Document Type	Document Number	Expiry Date (YYYYMMDD) (if applicable)
Name (exactly as it appears on the document)		

B. Name Linking Document(s) (Provide if the name you are using on this application is different than the name listed on your identity documents, legal documents (custody order, order of guardianship, etc.) or the proof of birth document of the child/dependent adult)

Name (exactly as it appears on the document)	Document Type



SECTION 6: Adoption Information (Complete this section ONLY if the child/dependent adult was adopted)

I believe the child/dependent adult has entitlement to Indian status through (select all that apply)

- The adoptive mother The adoptive father The birth mother The birth father

Adoptive Mother

Family Name	Given Name(s)	Date of Birth (YYYYMMDD)
-------------	---------------	--------------------------

Adoptive Father

Family Name	Given Name(s)	Date of Birth (YYYYMMDD)
-------------	---------------	--------------------------

Birth Mother (if known)

Family Name	Given Name(s)
-------------	---------------

Birth Father (if known)

Family Name	Given Name(s)
-------------	---------------

▶ If you believe the child/dependent adult is entitled to Indian status through his/her adoptive parent(s), complete the Family Information section below with the adoptive parents' information.

▶ If you believe the child/dependent adult is entitled to Indian status through his/her birth parent(s), complete the Family Information section below with the birth parents' information (if available).

SECTION 7: Family Information

A. Father

Family Name	Family Name at Birth (if different)	Given Name(s)
Date of Birth (YYYYMMDD)	First Nation/Band Name	First Nation/Band (3 digits) Number or Registration (10 digits) Number
Was the father adopted? <input type="radio"/> Yes <input type="radio"/> No <input type="radio"/> Unknown <input type="checkbox"/> Parent not stated on the birth document		

B. Mother

Family Name	Family Name at Birth (if different)	Given Name(s)
Date of Birth (YYYYMMDD)	First Nation/Band Name	First Nation/Band (3 digits) Number or Registration (10 digits) Number
Was the mother adopted? <input type="radio"/> Yes <input type="radio"/> No <input type="radio"/> Unknown		

C. Maternal Grandparents (Provide information up to the first person registered. For example, if the mother is registered, information on grandparents and great-grandparents is not required)

Family Name	Family Name at Birth (if different)	Given Name(s)	Date of Birth (YYYYMMDD)	First Nation/Band Name or Registration Number	Adopted (Yes/No)
Grandfather					
Grandmother					
Great-Grandfather (1)					
Great-Grandmother (1)					
Great-Grandfather (2)					
Great-Grandmother (2)					

D. Paternal Grandparents (Provide information up to the first person registered. For example, if the father is registered, information on grandparents and great-grandparents is not required)

Family Name	Family Name at Birth (if different)	Given Name(s)	Date of Birth (YYYYMMDD)	First Nation/Band Name or Registration Number	Adopted (Yes/No)
Grandfather					
Grandmother					
Great-Grandfather (1)					
Great-Grandmother (1)					
Great-Grandfather (2)					
Great-Grandmother (2)					

Additional Family Information (optional): List the names of other registered relatives such as brothers, sisters, aunts, uncles, cousins. (Add separate pages if additional space is required)

SECTION 8: Photo to Appear on the Secure Certificate of Indian Status (SCIS)

► Select what applies to you.

- Two (2) unaltered, identical, Canadian passport-style photographs are included SCIS not requested

SECTION 9: Declaration and Signature of Parent(s)/Legal Guardian(s)

► Failing to sign and date the declaration will delay the processing of the application.

I solemnly declare that I am the parent/legal guardian of the child/dependent adult. All statements made in this application are true, all documents provided to support this application are unaltered, and the enclosed photographs (if requesting a Secure Certificate of Indian Status) are a true likeness of the child/dependent adult. I have read and understand the Notice to Applicants and the *Privacy Act* Statement.

If the child/dependent adult is eligible, I request that _____ be registered in
(Print name of child/dependent adult)

the Indian Register and, if applicable, that his/her name be entered on a First Nation/Band List, as provided for under the *Indian Act*. I further request that a Secure Certificate of Indian Status be issued to the child/dependent adult (if applicable).

Signature of Applying Parent/Legal Guardian	Date (YYYYMMDD)	Signature of Other Parent/Legal Guardian	Date (YYYYMMDD)
X		X	

SECTION 10: Indian Registration Administrator (IRA)

► If an IRA assisted in completing this form, he or she must complete and sign this section.

Name	First Nation/Band Number or Initiator Code	IRA Signature	Date (YYYYMMDD)
		X	



INSTRUCTIONS
APPLICATION FOR REGISTRATION ON THE INDIAN REGISTER AND
FOR THE SECURE CERTIFICATE OF INDIAN STATUS (SCIS)
(FOR CHILDREN 15 YEARS OF AGE OR YOUNGER OR DEPENDENT ADULTS)

GENERAL INFORMATION

► **This guide provides information to complete the application for registration and for the Secure Certificate of Indian Status for a child (15 years of age or younger) or a dependent adult (form 83-171E), including applications made under:**

- Bill C-31: *An Act to Amend the Indian Act*;
- Bill C-3: *Gender Equity in Indian Registration Act*;
- Bill S-3: *An Act to Amend the Indian Act in response to the Superior Court of Quebec decision in Descheneaux c. Canada (Procureur général)*; and
- All other applications under *the Indian Act*.

► **TO OBTAIN FORMS OR INFORMATION ON ELIGIBILITY CRITERIA**, visit Canada.ca/Indian-status, or call 1-800-567-9604.

► To complete the application, it may be necessary to include a **Guarantor Declaration (form 83-169E)** or a **Statutory Declaration in Lieu of Guarantor (form 83-170E)**. A Guarantor or Statutory Declaration is required if you send the application by mail.

A guarantor is a person who can confirm the identity of the parent or legal guardian who is completing the application. To act as guarantor, the person must meet the criteria detailed on the Guarantor Declaration form.

If an eligible guarantor is not available, the parent or legal guardian who is completing the application must provide two (2) references who can confirm his/her identity. The Statutory Declaration in Lieu of Guarantor form must be completed and signed before a Commissioner for Oaths, notary public or lawyer.

► **TO SUBMIT THE APPLICATION**, please review the instructions on the application form.

SECTION 1: INFORMATION ON THE CHILD OR DEPENDENT ADULT

- **The permanent address** is the home address of the child or dependent adult.
- **The address on reserve box** must be checked if the permanent address is located on reserve.
- **If you are applying for a child, you must indicate if there are legal documents pertaining to the custody or guardianship of the child** (such as a divorce judgment, a separation agreement, a custody or guardianship order). If there are such documents, photocopies of the most recent legal documents must be provided.
- **If you are applying for a dependent adult, a photocopy of the Order of Guardianship is required.** (An order of guardianship is a court order authorizing you to act and make decisions on behalf of the dependent adult.)



SECTION 2: DOCUMENT REQUIREMENTS FOR THE CHILD OR DEPENDENT ADULT

A. PROOF OF BIRTH DOCUMENT

Requirements:

- An **original proof of birth document is required**. The document will be returned to you within four (4) weeks of receiving your application. Photocopies or certified copies are not acceptable. (An original document is required to verify that the document is official, genuine and has not been altered.)
- A birth certificate listing the **names of the parent(s)** is required.
Note: If the child or dependent adult was adopted, you must provide an original birth certificate listing the names of the **adoptive parent(s)**.
- Any alteration to the document will make it unacceptable.
- **The document must be in English or French**. If the document is in another language, you must provide the original document and a translation into English or French. The translation must be done by a professional translator.

Acceptable proof of birth documents include:

- A Canadian birth certificate issued by a provincial or territorial vital statistics agency.
- A Quebec birth certificate issued by the Directeur de l'état civil after January 1, 1994. If you have a birth certificate that was issued before January 1, 1994, you must request a new one.
- A Quebec birth certificate with a place of birth outside of Quebec (elsewhere in Canada or in the United States) issued by the Directeur de l'état civil after January 1, 1994, with the mention "certifié conforme".
- A baptismal certificate is acceptable only for applicants born before 1952. It must be issued by a church and must contain the name, date of birth, sex, the parents' full names, and the date of issue.
- A Canadian vital statistics birth extract in compliance with current memoranda of understanding/information sharing agreements with vital statistics offices.
- A birth certificate issued in the United States by a state, county, city or town official authorized to do so by the state (for example, the Department of Health). Some states issue only certified copies, in which case these documents are acceptable.
- A birth certificate and registration of birth issued in a country other than Canada and the United States. Applicants must provide the original document as issued by their birth country and a translation into English or French, if the document is in another language. The translation must be done by a professional translator.

B. NAME-LINKING DOCUMENTS (if applicable)

- ▶ If the name of the child or dependent adult on the application form is different than the name listed on the proof of birth document, you must provide a legal document to link the previous name (as listed on the birth document) and the current name (as listed on the application form). Examples of name-linking documents include a legal name change certificate and an amended birth certificate with the current name of the child / dependent adult and the names of the parents.

Requirements:

- You may provide the **original** name-linking document. The document will be returned to you within four (4) weeks of receiving your application.
- A **photocopy** of the name-linking document is acceptable **if you also provide** a photocopy of a government-issued identity document with the child's or dependent adult's current name (for example, a health card issued by a province or territory).

SECTION 3: FIRST NATION / BAND CHOICE

- ▶ Complete this section if the child or dependent adult has the option of being affiliated with either the mother's or the father's First Nation/Band. Before making a selection, you may wish to contact these First Nations/Bands for more information on their membership processes and benefits.



SECTION 4: INFORMATION ON THE PARENT(S) OR LEGAL GUARDIAN(S)

- ▶ Either parent/legal guardian may complete the form as the **applying parent / legal guardian** when there are no legal custody or guardianship documents, or when legal documents provide for **joint** custody/guardianship of the child or dependent adult. Information about the other parent or legal guardian must be provided in the Other Parent/Legal Guardian section.
- ▶ If the other parent is deceased, include a photocopy of the death certificate.
- ▶ When legal documents provide custody/guardianship of the child or dependent adult to ONE person, only that person can complete the form as the **applying parent/legal guardian**. (The Other Parent/Legal Guardian section does not have to be completed.)

SECTION 5: DOCUMENT REQUIREMENTS FOR THE APPLYING PARENT OR LEGAL GUARDIAN

A. SUPPORTING IDENTITY DOCUMENTS (required only for the applying parent/legal guardian)

Requirements:

- Identity documents must be valid (not expired or altered in any way).
- Supporting identity documents must be in English or French. If they are in a language other than English or French, you must provide the document and a translation done by a professional translator.
- Photocopies of your supporting identity documents are acceptable, **provided you include a Guarantor Declaration form with the application**. The form must contain the signature of the guarantor. The guarantor must sign and date the photocopies of the front and back of your supporting identity documents, confirming that the original documents have been seen. **If you send the application by mail, it is recommended that you include photocopies of your supporting identity documents and a Guarantor Declaration form.**
- **If you are submitting the application in person, it is recommended that you bring your original identity documents.** Photocopies will be made on site and you will retain your original documents.

Acceptable Supporting Identity Documents:

Option 1 - You may provide **one (1) document** that contains **your full name, date of birth, photo and signature**, among these:

- A passport;
- A driver's license or enhanced driver's license issued by a province or territory;
- An identification card or enhanced identification card issued by a province or territory;
- A health card issued by a province or territory if it shows your full name, date of birth, photo and signature;
- A Canadian citizenship card issued prior to February 1, 2012;
- A Canadian permanent resident card with signature (issued before February 4, 2012);
- A Canadian military identification document;
- A U.S. permanent resident card.

Option 2 - You may provide **one (1) document** among these:

- Your Secure Certificate of Indian Status (SCIS) if the application is submitted no later than 12 months past the renewal date indicated on your SCIS.
- Your Certificate of Indian Status (CIS) if the application is submitted no later than 6 months past the expiry date indicated on your CIS.
- A provincial, territorial or federal Correctional Services identity document (with or without a signature);
- A social worker's employment identification document (with or without a date of birth and/or signature).



Option 3 - If you do not have a document listed under options 1 or 2, you may provide **more than one of the following documents that, when combined together, include your full name, date of birth, photo and signature:**

- A health card issued by a province or territory;
- A U.S. passport card;
- A NEXUS or FAST card;
- A government employee identification card;
- A Canadian permanent resident card without signature (issued after February 4, 2012);
- A firearms license;
- A U.S. Old Age Security card.

Option 4 - If you do not have more than one identity document that, when combined together, include your full name, date of birth, photo and signature, you must provide **one (1) document listed under option 3, and a Guarantor Declaration form**. The form must contain the signature of the guarantor. The guarantor must sign and date the back of one (1) of the photos and write the statement "this is a true likeness of (name of child or dependent adult)". If you include a photocopy of your identity document, the guarantor must also sign and date the photocopy of the front and back of the document.

The following documents are not accepted:

- Social Insurance / Old Age Security Card;
- Certificate of exemption (gas card);
- Commemorative citizenship certificate;
- Certificate of Canadian Citizenship (issued on or after February 1, 2012);
- Student identification card;
- Tribal or Band card;
- Pleasure boat license card;
- Bus pass;
- Blood donor card;
- Private health insurance card;
- Credit cards and other banking cards;
- Temporary identification card;
- Municipal identification card;
- Outdoors card;
- Library card.

B. NAME-LINKING DOCUMENTS (if applicable)

- ▶ If your name as listed on the application form is different than the name listed on your identity documents, on legal documents provided with the application or on the child's/dependent adult's proof of birth document, you must provide a legal document to link your previous name and your current name.
- ▶ A photocopy of name-linking document(s) is acceptable.

Acceptable name-linking documents include:

- A legal change of name certificate;
- A marriage certificate;
- A common-law relationship certificate (Manitoba);
- A certificate to dissolve a registered common-law relationship;
- A resumption of surname certificate;
- A court order (for example, a separation agreement or a divorce order/judgment) issued by a court of law in or outside Canada.
- An amended birth certificate with your current (new) name and the names of your parents.



SECTION 6: ADOPTION INFORMATION

- ▶ Complete this section **ONLY** if the child or dependent adult was adopted.
- ▶ Include a photocopy of the **Adoption Order** or a photocopy of a **letter from the Social Services authorities involved with the adoption** confirming the details of the adoption: the names of the adoptive parent(s), the adoptee's full name as it appears on the Adoption Order, and the date and place of the adoption.
- ▶ Include a signed and dated consent form giving the Indian Registrar permission to contact the Social Services authorities for information on the child's or dependent adult's birth ancestry. To obtain the consent form, please call 1-800-567-9604.
- ▶ Complete the Family Information section (section 7) with the adoptive parents' information if you believe the child or dependent adult is entitled to registration through them. If you believe the child or dependent adult is entitled to registration through his or her birth parents, provide the birth parents' information, if it is available to you.
- ▶ Please mail the application to the Adoption Unit at 10 Wellington Street, Gatineau, Quebec, K1A 0H4.

SECTION 7: FAMILY INFORMATION

Family information is important to determine entitlement to registration.

- ▶ Provide family information (genealogy) up to the first registered family member (for example, if the mother is registered, information on maternal grandparents and great-grandparents is not required).
- ▶ If available, provide the registration number (10-digit number) and Band name of family members. (The absence of registration numbers for family members could delay the processing of the application.)
- ▶ If you are not able to provide information on grandparents and great-grandparents, you may wish to provide information on other relatives in the Additional Family Information box. (Include information such as: last and first names, any known aliases or maiden/nee names, relationship, date of birth, Band name.)

SECTION 8: PHOTOS IF REQUESTING THE SECURE CERTIFICATE OF INDIAN STATUS

- ▶ Provide two (2) identical and unaltered Canadian passport-style photos of the child or dependent adult, taken within the last twelve (12) months from the date the application is submitted.

Note: U.S. passport photo specifications do not meet the photo requirements for the Secure Certificate of Indian Status.

The photos must meet the following requirements:

- Photo size: 50 mm wide x 70 mm high (2 inches wide x 2 7/8 inches high).
- The face, from chin to crown of the head, must measure between 31 and 36 mm (1 1/4 inch and 1 7/16 inch).
- Photos must be original and not taken from an existing photograph.
- Photos must be printed on plain, high quality photographic paper. Heavyweight paper is not acceptable.
- The image must be clear, sharp and in focus. Photos can be in color or black and white.
- Facial features must appear clearly against a white or light-coloured background.
- Shadow across the face or shoulders, around the ears or in the background is not acceptable.
- The photo must show a full front view of the face and top of the shoulders squared to the camera, and centred in the photo.
- Hats and other head coverings must not be worn, except for religious or medical reasons. If worn, the hat or other head covering must not cast shadows on the face and the full face must be clearly visible.

- The face must show a neutral expression and the mouth must be closed.
- Eyes must be open and clearly visible. Glasses, including tinted prescription glasses, are acceptable as long as the eyes are clearly visible and there is no glare or reflection on the face or glasses. Sunglasses are not acceptable.
- For a child, the photo must show the child's head and shoulders only. Parent's or child's hands must not appear in the photo.
- For newborns, the photo may be taken while the child is sitting in a car seat, as long as a white blanket is placed over the seat behind the child's head.

The following must appear on the back of one (1) photo:

- The name and address of the studio or person who took the photo, and the date the photo was taken (not the date the photo was printed).
- If you are submitting the application by mail, your guarantor must sign and date the back of the photo, and write the statement: "this is a true likeness of (name of child or dependent adult)".

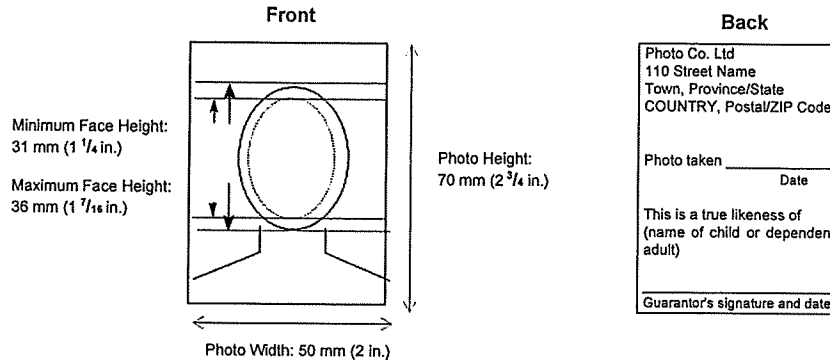

Image is not the actual size (refer to specified measurements)

SECTION 9: DECLARATION AND SIGNATURE OF PARENT(S)/LEGAL GUARDIAN(S)

Please do not forget to date and sign the Declaration and Signature section to avoid delays in the processing of the application.

- ▶ The signature of both parents/legal guardians is required when there are no legal custody or guardianship documents, or when legal documents provide for joint custody/guardianship of the child or dependent adult.
- ▶ If the other parent is deceased, include a photocopy of the death certificate.
- ▶ When legal documents provide custody/guardianship of the child or dependent adult to ONE person, only that person can sign as the applying parent/legal guardian. The signature of the other parent is not required.